

■ **DATA SHEET MONITORS M2 – M7**
 WITH FOAM PIPE (FP)
 OR FOAM PIPE AND DEFLECTOR (FPD).

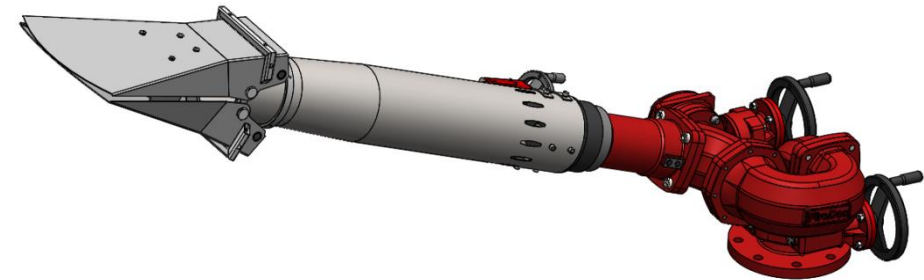

■ **1. GENERAL TECHNICAL DATA.**

Type series	M2	M3	M4	M5	M7
Max. water flow rate	2500 l/min	4000 l/min	8000 l/min	12 000 l/min	20 000 l/min
Connecting flange (optionally)	DN65 PN16 DN80 PN16	DN80 PN16 DN100 PN16	DN100 PN16 DN150 PN16	DN150 PN16 DN200 PN16	DN200 PN16
	ASME B 16.5 150 lbs. 2 ½" ASME B 16.5 150 lbs. 3"	ASME B 16.5 150 lbs. 3" ASME B 16.5 150 lbs. 4"	ASME B 16.5 150 lbs. 4" ASME B 16.5 150 lbs. 6"	ASME B 16.5 150 lbs. 6" ASME B 16.5 150 lbs. 8"	ASME B 16.5 150 lbs. 8"
Elbow (optionally) 	G4" Male thread	G4" Male thread	G5" Male thread	G5" Male thread	-
Max. op. pressure	16 bar				

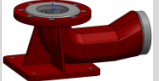

■ 2. SPECIFIC TECHNICAL DATA.

Hand lever version:

Hand lever	M2-L	M3-L	M4-L
Corresponding nozzle	FP2	FP4	FP8
Swivelling range	Horizontally 360° / vertically up to +90°		
Operating temperature	-40 °C up to +80 °C		

Hand wheel version:

Hand wheels	M2-MO	M3-MO	M4-MO	M5-MO	M7-MO
Corresponding nozzle	FP2 / FPD2	FP4 / FPD4	FP8 / FPD8	FP12 / FPD12	FP20 / -
Swivelling range	Horizontally 360° / vertically up to +90°				
Operating temperature	-40 °C up to +80 °C				

Also available as ATEX version with the following designation: Ex II 2G IIB c T4 / II 2D IIIB c T<130°C.

3. FOAM PIPE (FP)

FOAM PIPE WITH DEFLECTOR (FPD)

The foam pipe (“Foam Pipe” = FP) is used to produce low-expansion foam; the discharge of water, however, is also possible. In foam operation mode, both the aspirated air and the foam agent/water mixture result in the generation of foam. The foam pipe is typically used to produce heavy foam at foam expansion rates of up to 15 (depending on the foam agent type and the operational parameters).



The deflector (“Foam Pipe Deflector”) allows to form a two-dimensional spray jet as an alternative to the straight foam jet, enabling the foam discharge across a large surface. The linear drive mounted on the deflector allows stepless opening and closing also during operation.



The nozzle is factory-set to a fixed extinguishing agent flow rate in accordance with the available system pressure. If requested, this setting can be adjusted later on.

4. REACH AND REACTION FORCE.

Using the app at www.firedos.com/monitorapp, you can determine the reach curve and the reaction forces depending on your operating conditions.

INPUT PARAMETERS

MONITOR TYPE

Monitor with a maximum water flow rate of up to 2000 l/min.
Electric adjustment possible only.

NOZZLE TYPE

The multi-purpose nozzle (MPN) is used to discharge either water or premix at a low expansion rate. Stepless adjustment between hollow jet and spray jet is possible.

Flow rate

Pressure

Angle

Medium

OUTPUT PARAMETERS



Reach

Jet Reaction Force



Throw Height

PDF

■ 5. DIMENSIONS FOR VERSION WITH
HAND LEVER (-L).

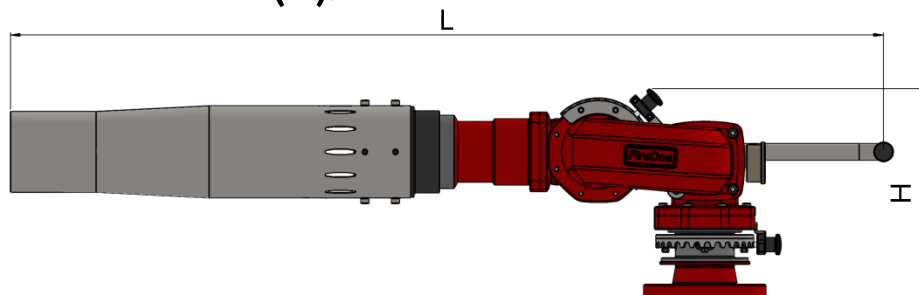

	Length L	Width W	Height H	Weight
M2-L / FP2	1455 mm	380 mm	300 mm	21 kg
M3-L / FP4	1690 mm	400 mm	340 mm	35 kg
M4-L / FP8	2245 mm	590 mm	570 mm	63 kg

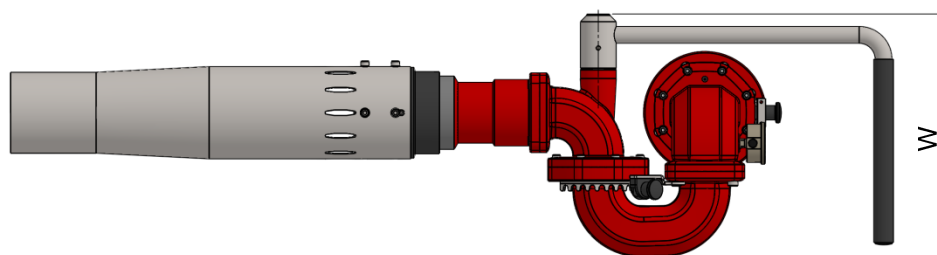

■ 6. DIMENSIONS FOR VERSION WITH HAND WHEELS (-MO).

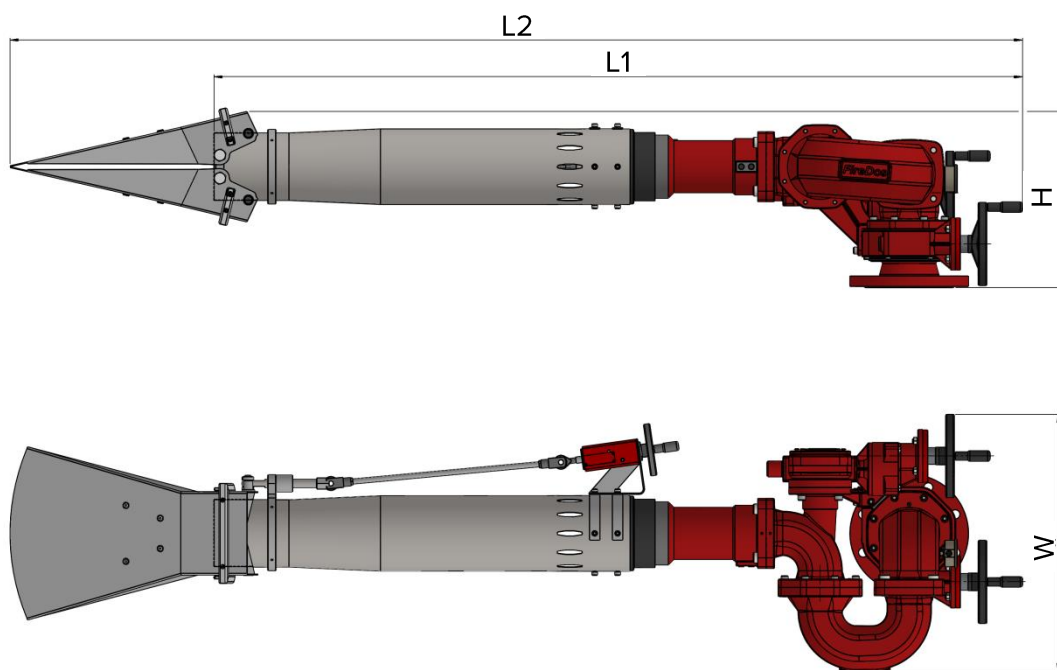

	Length L 1	Width W	Height H	Weight
M2-MO / FP2	1400 mm	440 mm	310 mm	25 kg
M3-MO / FP4	1610 mm	440 mm	360 mm	40 kg
M4-MO / FP8	1945 mm	620 mm	425 mm	69 kg
M5-MO / FP12	2315 mm	700 mm	555 mm	102 kg
M7-MO / FP20	2905 mm	890 mm	800 mm	161 kg

	Length L 2	Width W	Height H	Weight
M2-MO / FPD2	1780 mm	440 mm	310 mm	30 kg
M3-MO / FPD4	2025 mm	440 mm	360 mm	46 kg
M4-MO / FPD8	2435 mm	620 mm	425 mm	77 kg
M5-MO / FPD12	2940 mm	700 mm	555 mm	114 kg

■ 7. MATERIALS.

- Cast aluminium AlSi7Mg 0.3 with HC and powder coating
- AlMgSi1 with HC and powder coating
- Stainless steel V2A and V4A
- NBR
- Powder coating Red (RAL 3020) as a standard

■ 8. MANUFACTURER.

FireDos GmbH, Auf der Kaulbahn 6, 61200 Woelfersheim, Germany
Phone +49 (0) 6036 9796-0, Email: info@firedos.de

We reserve the right to make modifications at any time.
All figures are approximate and subject to the particular version/equipment.